

E023

HSS-E-PM Spiral Flute Machine Tap, UNC, ISO Standard

Machine tap with spiral flute suited for blind holes. Steam tempered surface acts to retain cutting fluid and prevent chip to tool welding.

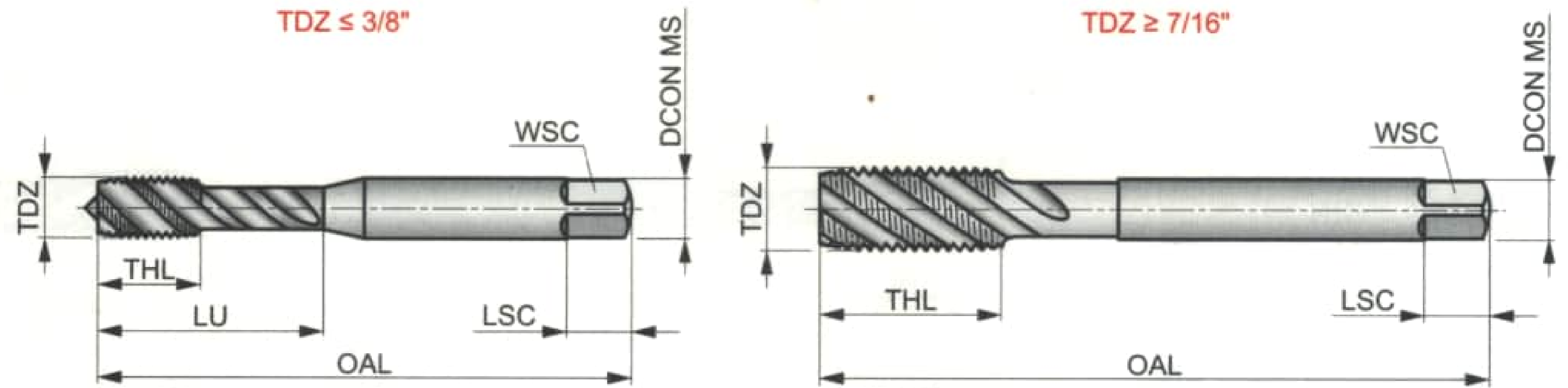

	ISO 529	2B
	2.5xD	HSS-E PM
C 2-3		λ 45°

Workpiece material group suitability and starting values for cutting speed (m/min).

P1.1 ■21	P2.2 ■15	P2.3 ■13	P3.2 ■9	P3.3 ■8	P4.1 ■7	P4.2 ■5	M1.1 ■8	M1.2 ■6	M2.1 ■7	M2.2 ■5	M3.1 ■5	M3.2 ■4	M3.3 ■3
M4.1 ■3													

Product	TDZ	TPI	TD (mm)	OAL (mm)	THL (mm)	DCON MS (mm)	WSC (mm)	LSC (mm)	NOF	PHD (mm)	LU (mm)
E0232-56	2	56	2.184	44.5	9.5	2.80	2.24	5	2	1.85	9.50
E0234-40	4	40	2.845	48.0	6	3.15	2.50	5	3	2.35	14.00
E0235-40	5	40	3.175	48.0	6	3.15	2.50	5	3	2.65	12.50
E0236-32	6	32	3.505	50.0	6	3.55	2.80	5	3	2.85	16.00
E0238-32	8	32	4.166	53.0	7	4.50	3.55	6	3	3.50	17.00
E02310-24	10	24	4.826	58.0	8	5.00	4.00	7	3	3.90	20.00
E02312-24	12	24	5.486	62.0	12	5.60	4.50	7	3	4.50	21.00
E0231/4	1/4	20	6.350	66.0	10	6.30	5.00	8	3	5.10	28.00
E0235/16	5/16	18	7.938	72.0	12	8.00	6.30	9	3	6.60	31.00
E0233/8	3/8	16	9.525	80.0	15	10.00	8.00	11	3	8.00	34.00
E0237/16	7/16	14	11.112	85.0	19	8.00	6.30	9	3	9.40	-
E0231/2	1/2	13	12.700	89.0	19	9.00	7.10	10	3	10.80	-
E0235/8	5/8	11	15.875	102.0	24	12.50	10.00	13	4	13.50	-
E0233/4	3/4	10	19.050	112.0	29	14.00	11.20	14	4	16.50	-
E0237/8	7/8	9	22.225	118.0	29	16.00	12.50	16	4	19.50	-
E0231	1"	8	25.400	130.0	35	18.00	14.00	18	4	22.25	-